

THIS DRAWING IS UNPUBLISHED
 DIFFUSION RESTREINTE

RELEASED FOR PUBLICATION
 LIBRE A LA DIFFUSION

2011

ALL RIGHTS RESERVED.
 TOUS DROITS RESERVES

© COPYRIGHT 2011 by Tyco Electronics Corporation

LOC		DIST		REVISIONS				
P	LTR REV	DESCRIPTION MODIFICATIONS	DATE	DWN DESS	APVD APPR			
	A	CREATION	25-Feb-13	BH	-			

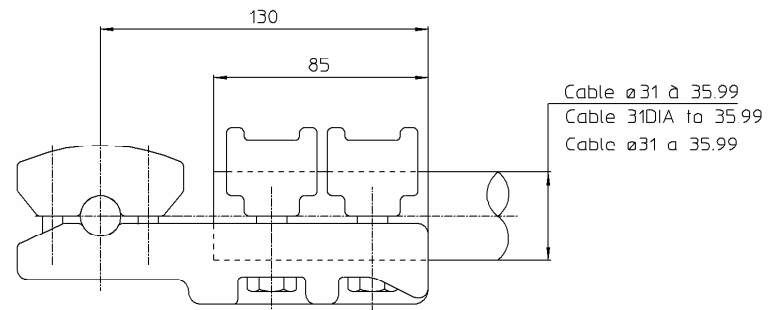

Cable ø12 à 15.99
 Cable 12DIA to 15.99
 Cable ø12 a 15.99

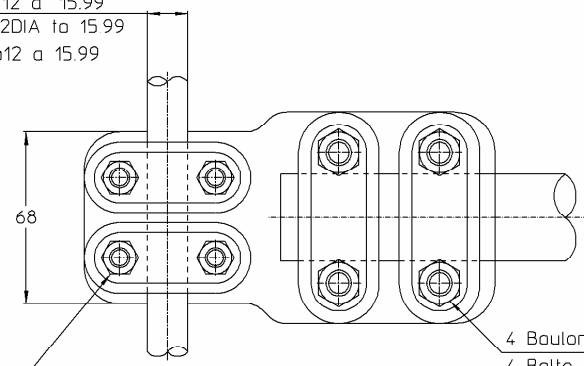

20 Nm { 4 Boulons ø8 acier inox A2
 4 Bolts 8DIA stainless steel A2
 4 Tornillos ø8 acero inoxidable A2

4 Boulons ø10 acier inox A2
 4 Bolts 10DIA stainless steel A2
 4 Tornillos ø10 acero inoxidable A2 } 37 Nm

THIS DRAWING IS A CONTROLLED DOCUMENT. <small>CE PLAN EST UN DOCUMENT CONTROLE PAR TYCO ELECTRONICS CORPORATION IL EST SUSCEPTIBLE D'ETRE REUSE POUR OBTENIR LA SERVICE TECHNIQUE. CONTACTER LE SERVICE TECHNIQUE DE TYCO ELECTRONICS SHEL SAS 21200 GENEVY-D'AUVERGNE, FRANCE.</small>		DWN /DESSINE HUARD	25-Feb-13	 TE connectivity SIMEL PRODUCTS			
DIMENSIONS: mm		CHK/VERIFIE -	APVD/APPROUVE -			NAME TITRE T 82 15 35	
TOLERANCES UNLESS OTHERWISE SPECIFIED PER TOLERANCES NON SPECIFIEES SELON : -		PRODUCT SPEC SPEC PRODUIT 02BFC0031	APPLICATION SPEC SPEC APPLICATION -	SIZE FORMAT A3	CAGE CODE 00779	DRAWING NO No PLAN C=2233757	RESTRICTED TO RESERVE A -
MATERIAL MATIERE -	FINISH FINITION -	WEIGHT MASSE APPROX 1 kg	CUSTOMER DRAWING /PLAN CLIENT	UNQUEMENT POUR REFERENCE	SCALE EHELLE 1/2	SHEET FEUILLE 1 OF DE 1	REV A

ITEM: ...2.....